

Dimension sheet for ROBA®-roll continuous slip clutch (M.140.01.GB)

Type 140.300
Adjustment with
6 hexagon socket set screws

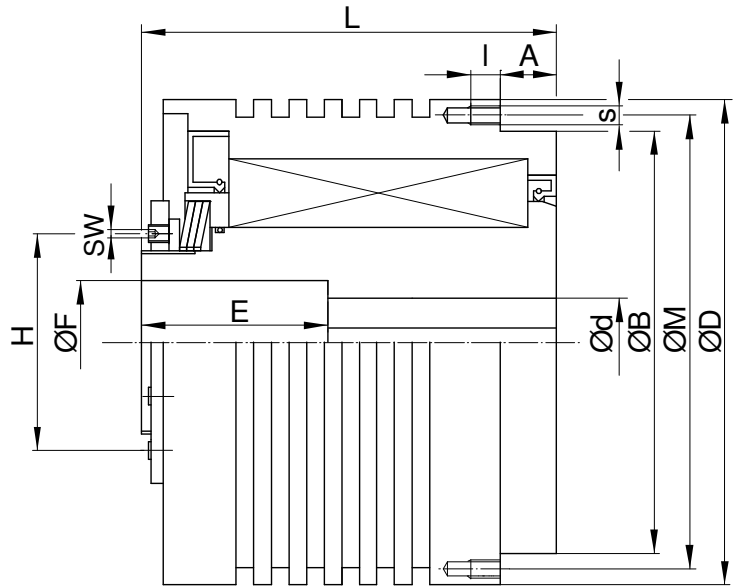

Type 140.006
Adjusting nut for
easy manual adjustment

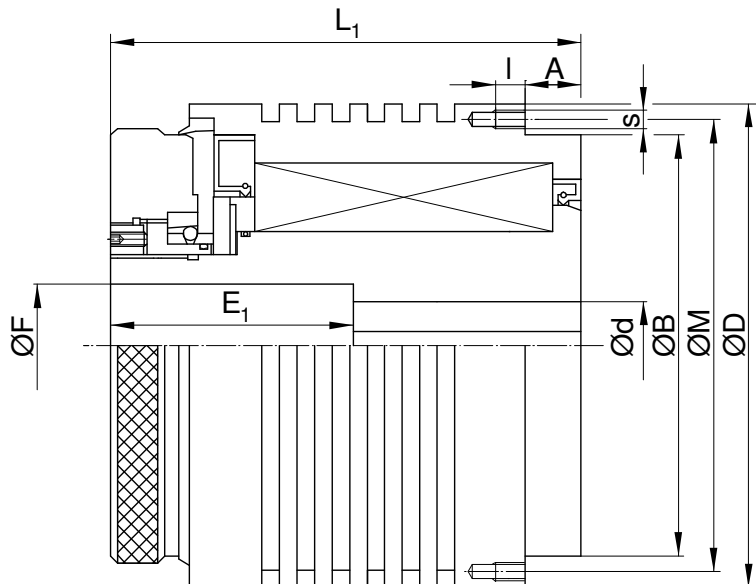

Technical data and dimensions

Size	Torque M_R ¹⁾ [Nm]	Relative speed n_{Rmax} [rpm]	A	B _{h8}	D	d _{max}	Standard bore d _{F7 2)}
1	2 – 5	350	16	120	138	30	25
3	3,5 – 12						
5	5 – 18						
7	7 – 24						

Size	E	E ₁ 6 x 60°	F	H	SW 4 x 90°	L	L ₁	I	M	s 4 x 90°
1	14	30	36	60	3	78	95	10	129	M5
3	33	49				97	114			
5	53	70				118	135			
7	89	107				154	172			

1) Other torque ranges on request
2) Other bores on request

We reserve the right to make dimensional and design alterations.

Dimension sheet for ROBA[®]-roll continuous slip clutch (M.140.01.GB)

Function

Several axial-needle bearings are axially prestressed by means of the adjusting nut. The arising wear resistant rolling friction generates an uniform and continuously adjustable slip torque. The ROBA[®]-roll continuous slip clutch can be used both in slipping and synchronous operation contrary to the most other systems, as the torque to be transmitted is also kept with the relative speed 0. The maximum permissible relative speed n_R depends on the adjusted torque M_R (see performance characteristic diagram).

Application

ROBA[®]-roll continuous clip clutches are mainly used in winding drives and conveyor systems.

Performance characteristic diagram $M_R \cdot n_R$

(for permanent temperatures 80 – 90 °C at the housing ED = 75 %)

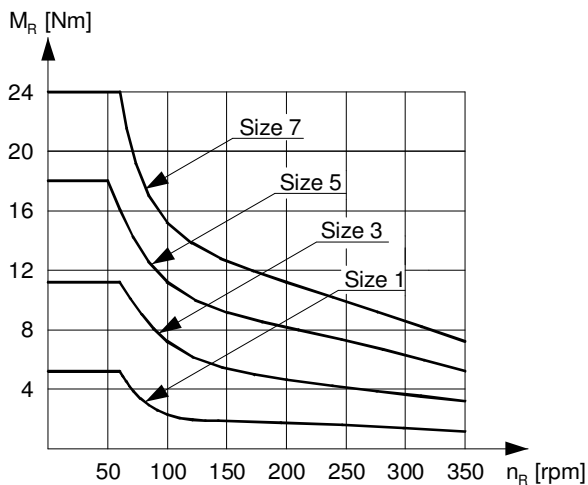

Special features

- Detachable solution ready to be installed
- Maintenance-free
- Easy torque adjustment (with frequent modification the design with manual adjustment should be preferred)
- Insensitive against environmental influences
- Slip torque being extensively independent from speed
- Can also be used as constant torque clutch

Design

ROBA[®]-roll continuous slip clutches are sealed all around, protected against corrosion and filled with oil. Thereby, torque variations are extensively excluded due to environmental influences.

The height of the maximum permissible relative speed n_R between hub and housing depends on the set torque M_R .

The curves shown on the performance characteristic limit the range where the clutch may be operated.

If the ROBA[®]-roll is operated above the limit curve, shown in the range of the performance characteristic diagram, an unacceptable high heating of the clutch arises.