

with ball screw and integrated double linear guide

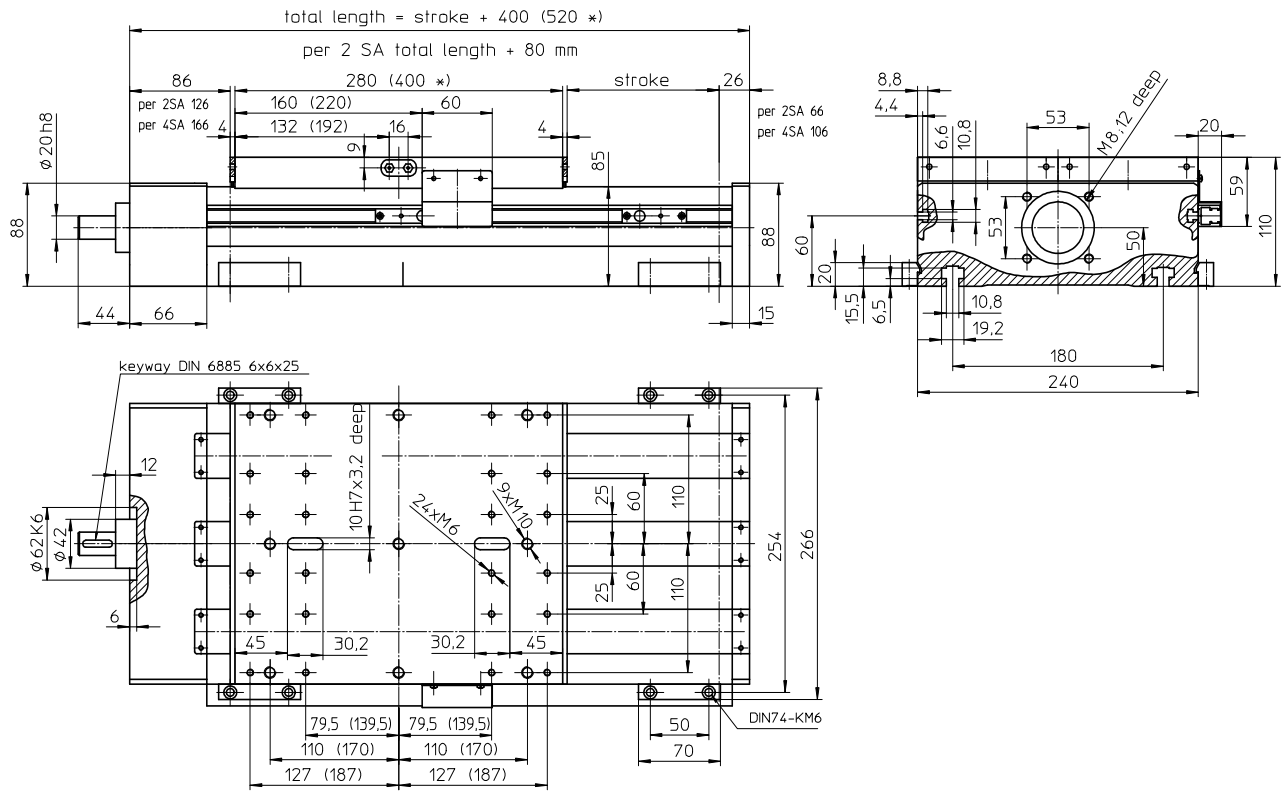

Weights

Basic length, no stroke:
100 mm stroke:
Carriage:
Idle torque:

SSS

26.00 kg
3.40 kg
10.20 kg
2.80 Nm

Technical data

Linear speed: 0.1 - 2.0 m/s **
Repeatability: ± 0.03 mm (ball screw)
Acceleration: max. 20 m/s²
Mass inertia: 4.5 kgcm²/m
Drive element: **ball screw drive:**
diameter: 32 mm
pitch: 5, 10, 20, 40 mm
Total length: up to 4000 mm

Loads and load moments

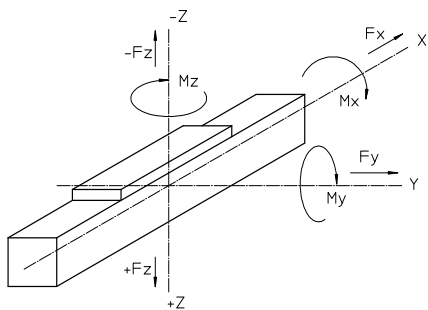

Type	with linear guide (SSS)
Load	dynamic [N]
F_x	12000
F_y	6000
F_z	12000
-F_z	8000
Load moment	dynamic [Nm]
M_x	4500
M_y	6000
M_z	4500

Screw supports SA

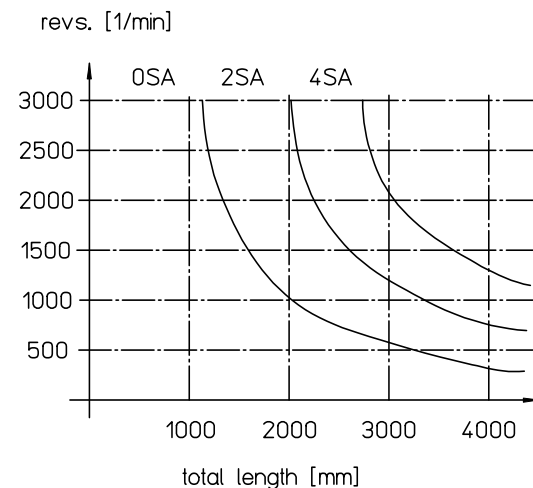

* data in () refers to 400 mm long carriage
** max. data for ball screw 3240