

Drives and drive components

Couplings

Flexible couplings RA, RG

The torque is transmitted by interlocked, elastic couplings, which compensate for slight axial displacement, radial offset and angular offset. Standard gear rim 92 Shore A.

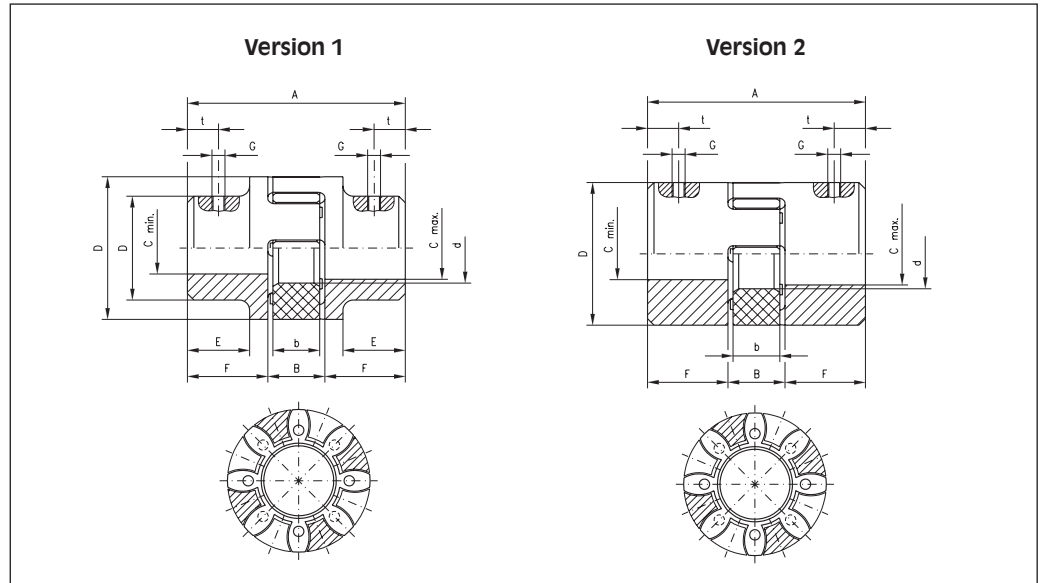

Size	Version	Max. torque [Nm]	Dimensions [mm]										Offsets				Set-screw tapping		Max. weight d. [kg]
			A ₁	E	F	B	b	D ₁	D	d	C _{min} ¹⁾	C _{max} ¹⁾	max. axial offset ΔK_a [mm]	max. radial offset n=1500 1/min. ΔK_r [mm]	max. angular offset at n = 1500 1/min ΔK_w [mm]		Dim. G	Dim. t	
RA 14	2	7.5	35	-	11	13	10	-	30	10	6	15	1.0	0.17	1.2	0.67	M4	5	0.05
RA 19	1	10	66	20	25	16	12	32	40	18	10	19	1.2	0.20	1.2	0.82	M5	10	0.15
RA 19/24	2	10	66	-	25	16	12	-	41	18	19	24	1.2	0.20	1.2	0.82	M5	10	0.15
RA 24	1	35	78	24	30	18	14	40	55	27	14	24	1.4	0.22	0.9	0.85	M5	10	0.25
RA 24/28	2	35	78	-	30	18	14	-	56	27	22	28	1.4	0.22	0.9	0.85	M5	10	0.35
RA 28	1	95	90	28	35	20	15	48	65	30	14	28	1.5	0.25	0.9	1.05	M6	15	0.40
RA 28/38	2	95	90	-	35	20	15	-	67	30	28	38	1.5	0.25	0.9	1.05	M6	15	0.55
RA 38	1	190	114	37	45	24	18	66	80	38	16	38	1.8	0.28	1.0	1.35	M8	15	0.85
RA 42	1	265	126	40	50	26	20	75	95	46	28	42	2.0	0.32	1.0	1.70	M8	20	1.2
RA 48	1	310	140	45	56	28	21	85	105	51	28	48	2.1	0.36	1.1	2.00	M8	20	1.7
RG 55	1	410	160	52	65	30	22	98	120	60	30	55	2.2	0.38	1.1	2.3	M10	20	7.3
RG 65	1	625	185	61	75	35	26	115	135	68	40	65	2.6	0.42	1.2	2.70	M10	20	11.0
RG 75	1	975	210	69	85	40	30	135	160	80	40	75	3.0	0.48	1.2	3.30	M10	25	17.9
RG 90	1	2400	245	81	100	45	34	160	200	100	50	90	3.4	0.50	1.2	4.30	M12	30	28.5

¹⁾ Not all intermediate sizes are listed in this catalogue. Further sizes on request.

Offsets

On the standard and large hubs, RA 14-48, the tapped hole (G) for the set screw is opposite the groove. Set screws conform to DIN 916, with serrated, annular cutting edge.

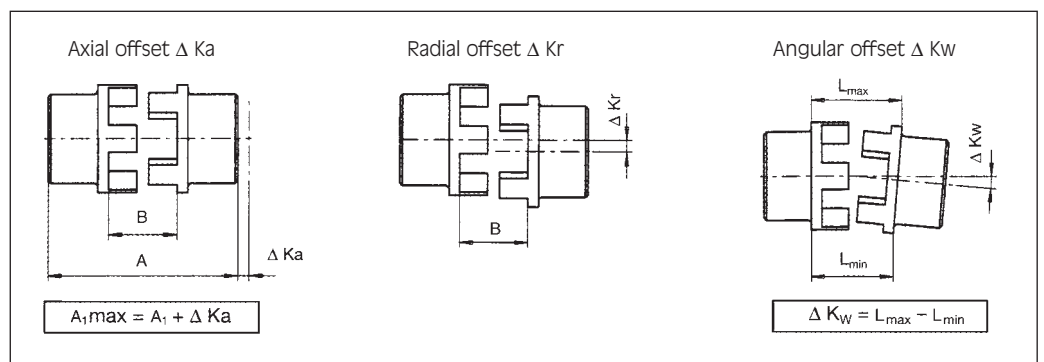

Drives and drive components

Universal joint shafts

Universal joint shafts GX

Universal joint shafts are used to connect several worm gear screw jacks together. The shafts attenuate noise, vibrations and impacts and compensate for axial, radial and angular errors. They offer exceptional torsional rigidity, high temperature and oil resistance and are particularly suitable where long lengths and/or high speeds are a factor. Elastic articulated shafts are maintenance-free; the central section can be removed radially (to the side) without axial displacement of the connected units. They are supplied as a length of tube (dimension L to be specified by customer) fitted with coupling assemblies at both ends. Pillow blocks are generally not required, except for very long connections.

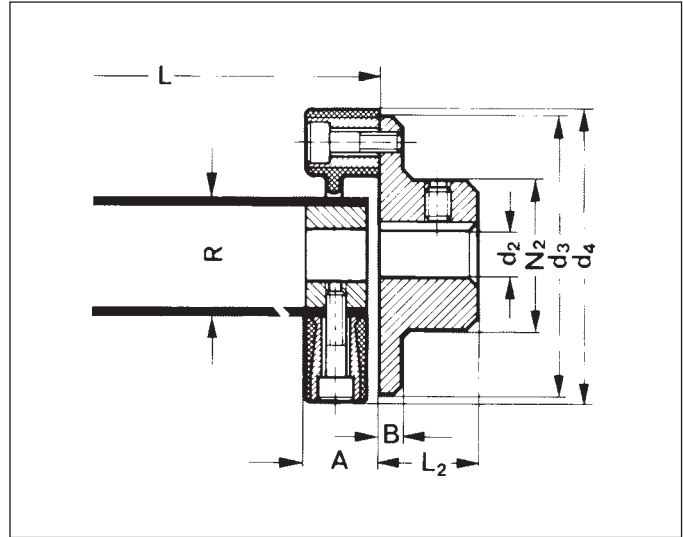

Size	M ¹⁾ [Nm]	Dimensions [mm]									Weight	
		A	B	d _{2 min}	d _{2 max}	d ₃	d ₄	L ₂	N ₂	R	m ₁ ²⁾ [kg]	m ₂ ³⁾ [kg/m]
GX 1	10	24	7	10	25	56	56	24	36	30	0.47	1.05
GX 2	30	24	8	14	38	85	88	28	55	40	1.06	1.42
GX 4	60	28	8	16	45	100	100	30	65	45	2.31	1.61
GX 8	120	32	10	20	55	120	125	42	80	60	3.55	2.16
GX 16	240	42	12	22	70	150	155	50	100	70	6.16	2.53
GX 25	370	46	14	22	85	170	175	55	115	85	9.5	3.09
GX 30	550	58	16	28	100	200	205	66	140	100	15.21	3.64

1) Transmittable torque in Nm

2) m₁ = Weight without central section

3) m₂ = Weight of central section per metre

Shaft diagramm

as a function of length and speed

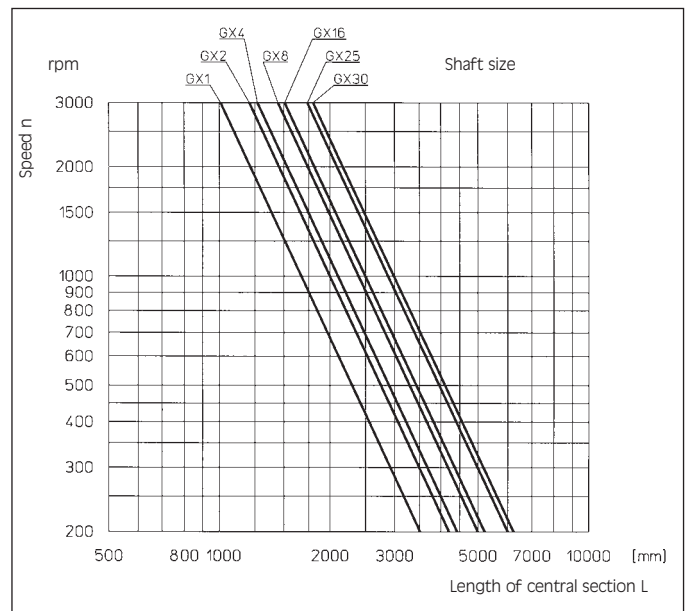

Drives and drive components

Length of the universal joint shaft for MULI® with companion flange

MULI® 1

with DKWN companion flange (10–20)

Starting torque of the tensioning element 1.2 Nm

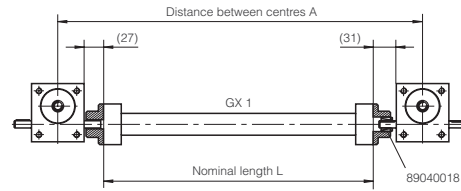

$$L = A - 130$$

MULI® 2

with DKWN companion flange (14–26)

Starting torque of the tensioning element 2.1 Nm

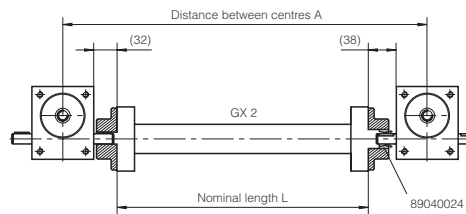

$$L = A - 155$$

MULI® 3

with DKWN companion flange (16–32)

Starting torque of the tensioning element 4.9 Nm

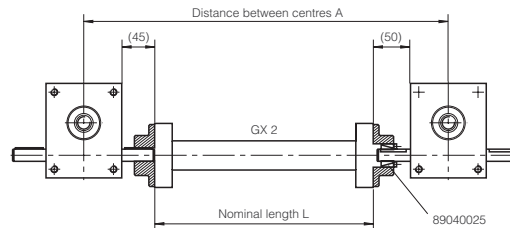

$$L = A - 200$$

MULI® 4

with DKWN companion flange (20–38)

Starting torque of the tensioning element 9.7 Nm

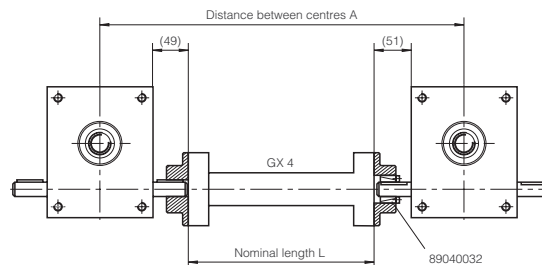

$$L = A - 245$$

MULI® 5

with DKWN companion flange (25–47)

Starting torque of the tensioning element 16.5 Nm

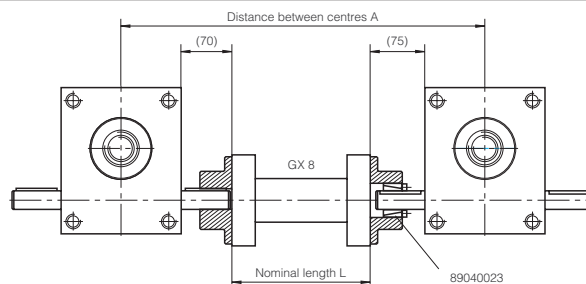

$$L = A - 310$$

Drives and drive components

Connecting Shafts, Series VW

Connecting shafts Series VW

The Series VW connecting shafts are rigid shafts with an engaging groove at each end. For greater distances and diameters of axle, some of these shafts are available as tubular shafts. The holes in the couplings must be drilled to fit the diameter of the shaft. (Torques see chart "couplings" on page 29).

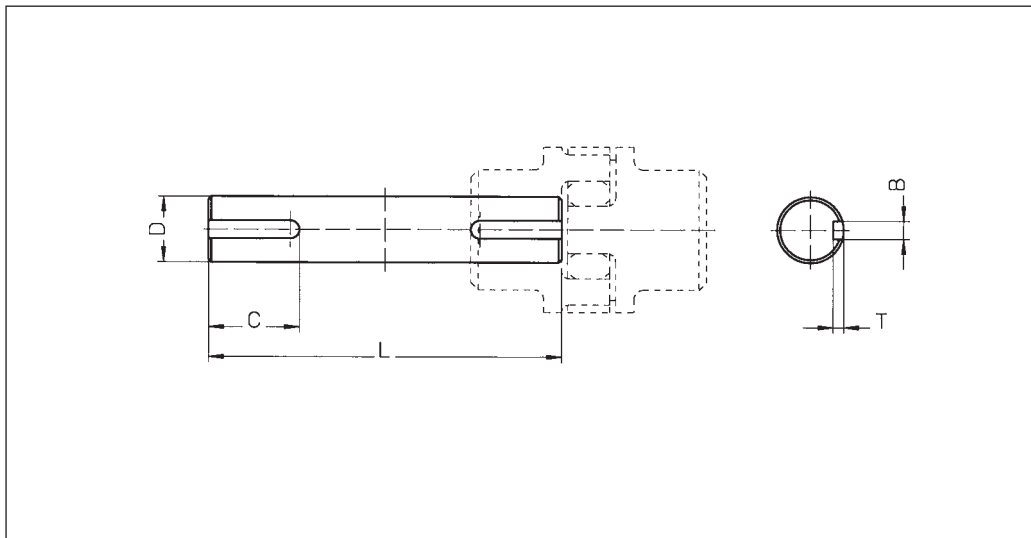

Size	D	C	B	T	Ident No. connecting shaft
VW 20	20	30	6	3.5	9204200003
VW 25	25	35	8	4	9204200006
VW 30	30	40	8	4	9204200007
VW 35	35	40	10	5	9204200008
VW 40	40	50	12	5	9204200009
VW 45	45	50	14	5.5	9204200010
VW 50	50	70	14	5.5	9204200011

Connecting shaft diagram

as a function of length and revs.

